



United Technologies
turn to the experts 

Package Rooftop Units – 60Hz



Quality Assurance
Certificate Reg. No:
04 100 950420



Subject to change without notice
Manufacturing point: Jeddah, Saudi Arabia
Nearest port of embarkation: Jeddah Islamic port
Product classification: Commercial

Product Data Catalog

50ZPM – 60Hz **Unit Size 3.0 – 5.0 Tons** **HFC R-410A Refrigerant**

The 50ZPM units are single side discharge rooftop cooling unit utilizing electric heat as an option. Units are pre-wired, pre-charged with R-410A refrigerant, and tested at the factory. These units can be placed on the side of a building or can be placed on a roof without roof curbs. Each unit is designed to occupy a minimal space. Piping and drain connections are readily accessible.

The 50ZPM unit is a packaged air conditioner manufactured for housing, residential, and light commercial applications. The 50ZPM unit design is the result of our firm commitment to the development of the finest air conditioners that modern technology can offer.

TABLE OF CONTENTS

Features / Benefits.....	2
Model No. Nomenclature	3
AHRI Capacity Ratings / Sound Power Level.....	4
Physical Data	5
Base Unit Dimensions	7
Selection Procedure	8
Cooling Capacities	9
Performance & Accessories	12
Electrical Data.....	13
Typical Wiring Schematic	14
Typical Installation	16
Application Data / Operating Sequence	17
Guide Specifications	18

FEATURES / BENEFITS

Factory-Assembled Package is a compact, fully self-contained, electric cooling unit with horizontal supply and return ducts. The 50ZPM units are available in three standard cooling sizes to meet residential and light commercial requirements. Unit installs easily on a ground level pad.

Easy to Install 50ZPM units are small, compact, and easy to handle. Every 50ZPM unit has an identical 32x51-in. (813x1295 mm) footprint. The concise design uses less sheet metal and makes the 50ZPM units lighter than other units. The unit can be easily positioned on the job site with the hand holds built into the unit base-pan.

Aerodynamic Fan Blade Design reduces the overall sound power level to as low as 74.4dBA.

Service Access makes installation and maintenance quicker and easier. The 50ZPM units are designed to be serviced from both the side and front. The design allows easy access for installation and maintenance procedures on the unit. Routine maintenance task time such as coil cleaning is minimized with the multiple access side panels.

Durable Pre-Painted Galvanized Steel Cabinet protects against harsh weather with watertight construction and corrosion resistant finish. The paint treatment process ensures quality protection against the elements. A compact, low-profile design utilizes a louvered coil enclosure for protection against vandalism and hail damage.

Indoor Air Quality is designed into the 50ZPM units. A sloped drain pan minimizes the amount of standing water inside the unit, which limits mold and mildew growth. The drain pan is made of a rust-proof material and will not deteriorate or release foreign matter into the airstream.

Refrigerant System is designed to provide dependability. Liquid refrigerant filter driers are used to promote clean, unrestricted operation. Each unit leaves the factory with a full refrigerant charge. Refrigerant service connections make checking operating pressures easier.

Durable, Dependable, Compressors are designed for high efficiency. Each compressor is hermetically sealed against contamination to help promote longer life and dependable operation. Vibration isolation provides quiet operation. Compressors have internal overcurrent protection.

Direct-Drive Multispeed, Blower Motor is standard on all models. It's high efficiency design ensures high performance with most duct systems.

Accessory Electric Heaters are available in a variety of sizes for the 50ZPM. These heaters are comprised of a separate heater module mounted on the blower inlet and remote mounted controls located in the unit control box. Single point electrical connections are available for powering both the heater and the unit.

MODEL NUMBER NOMENCLATURE – 50ZPM – R410A SERIES

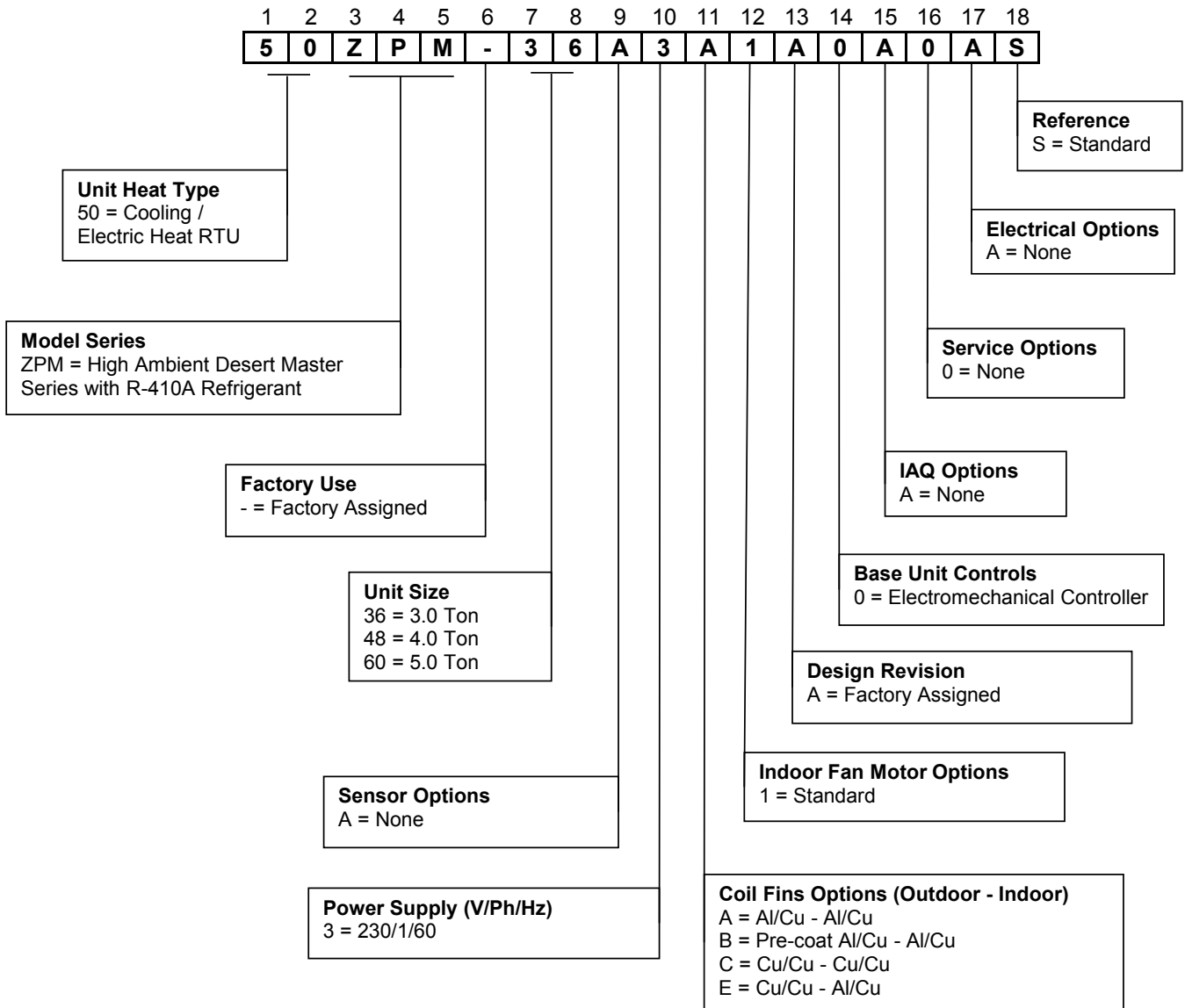

AHRI CAPACITY RATING

50ZPM Unit	Unit Size (Ton)	Net Cooling Capacity (BTU/hr)	EER	Standard Air Flow Rate CFM	Standard m3/hr	Standard L/S
36	3.0	35000	12.00	1350	2038	566
48	4.0	48000	11.20	1600	2717	755
60	5.0	55000	11.20	1800	3056	849

Legend:

AHRI - Air Conditioning, Heating and Refrigeration Institute

EER - Energy Efficiency Ratio

CFM - Cubic Feet per Minute

L/s - Liters per Second

BTU - British Thermal Unit

Notes:

1. Rated in accordance with AHRI Standards 210/240 and SASO 2874/2016
2. Ratings are net values, reflecting the effects of circulating fan heat
3. Rating are based on: Cooling Standard: 80 F db, 67 wb indoor entering-air temperature and 95 F db air entering outdoor unit

SOUND POWER LEVELS

50ZPM Unit	Unit Sound (dB) - Typical Octave Band Spectrum								
	Rating (dBA)	63	125	250	500	1000	2000	4000	8000
36	74.4	68.0	69.5	72.5	71.5	69.5	66.5	63.0	59.0
48	75.6	69.0	68.5	68.0	72.5	71.5	68.0	65.0	59.0
60	77.6	63.0	65.0	68.5	74.5	74.4	69.4	64.5	55.0

Legend:

dBA - Decibel A-Weighted

PHYSICAL DATA - ENGLISH

Unit 50ZPM	36	48	60
Unit Size (Ton)	3.0	4.0	5.0
Unit Dimensions - in	50.98 x 31.99 x 34.61	50.98 x 31.99 x 38.62	50.98 x 31.99 x 46.62
Unit Operation Weight - LBS	279	305	352
Refrigeration System			
Compressor No.# / Type	1 / Scroll		
Refrigerant Type	Puron ® R410A		
Circuits No.#	1		
Charge - LBS	5.07	5.78	6.75
Metering Device / ORIFIC OD (in)	Piston / 0.067	Piston / 0.082	TXV / N.A
Filter Drier Qty	1		
High Pressure Switch (Trip ±15/ Reset±25) - PSIG	650 / 420		
Low Pressure Switch (Trip ±5/ Reset±5) - PSIG	54 / 117		
Condenser Coil ⁽¹⁾			
Coil Type	7mm Helical Grooved Copper Tube, 0.74" Aluminum LSW Fins		
Standard Coil Material	Cu/Al		
Rows / Fins (FPI)	2 / 20		
Face Area (ft ²)	9.1	10.2	13.0
Coil Test Pressure (PSIG)	450		
Condenser Fan & Motor			
Approx. Air Flow Rate (CFM)	3000	3150	3700
Quantity	1		
Diameter (in) / No. of Blades	20 / 3		20 / 4
Motor Type	Induction Motor - Totally Enclosed		
Motor HP - RPM	1/4 - 1100		1/3 - 1100
Evaporator Coil ⁽²⁾			
Coil Type	3/8" Helical Grooved Copper Tube, 0.75" Aluminum LSW Fins		
Standard Coil Material	Cu/Al		
Rows / FPI	3 / 12		
Face Area (ft ²)	4.3	4.9	6.1
Coil Test Pressure (PSIG)	350		
Drain Pan Connection Size (in)	3 / 4		
Return Air Filter Qty / Size (in) - Recommended ⁽³⁾	1 / 24 x 30 x 1		1 / 24 x 36 x 1
Evaporator Fan and Motor Section			
Fan Quantity	1		
Fan Size (Diam. x L) (in)	11.0 x 9.0		12.0 x 10.5
Fan Type	Centrifugal - Forward Blade		
Drive Type	Direct Drive		
Motor Type	Electronically Commutated (ECM)		
Indoor Motor Factory Speed Setting	Medium		
Motor Quantity	1		
Maximum HP - Maximum Watt	1/2 - 530	3/4 - 780	1 - 1050
FLA	4.1	6.0	7.6
Efficiency %	78.5	80.0	79.0
No. Of Taps	3 - [1 (Low) - 2 (Medium) - 3 (High)]		
Tap Torque (OZ Ft) [L - M - H]	26.20 - 30.27 - 34.98	43.06 - 45.88 - 58.12	42.98 - 45.80 - 54.90
% of Full Output @ Tap [L - M - H]	65.49 - 75.69 - 87.45	71.76 - 76.47 - 96.86	53.73 - 57.25 - 68.63
Motor OFF- Delay (sec.) @ Tap [L - M - H]	60 - 30 - 0		
Nominal Air Flow Rate (CFM)	1350	1600	1800
External Static Pressure (In.W.G)	Up to 1.0"		
RPM Range	600 - 1200		
Motor Frame Size	NEMA Size - 48 Motor		

(1) Condenser Copper Coils : 21 FPI

(2) Evaporator Copper Coils : 13 FPI

(3) Field Supplied - Field Installed Filter (Installed Outside The Unit In The Return Duct)

PHYSICAL DATA - SI

Unit 50ZPM	36	48	60
Unit Size (Ton)	3.0	4.0	5.0
Unit Dimensions - mm	1295.0 x 812.5 x 879	1295.0 x 812.5 x 981	1295.0 x 812.5 x 1184
Unit Operation Weight - kg	127	139	160
Refrigeration System			
Compressor No.# / Type	1 / Scroll		
Refrigerant Type	Puron ® R410A		
Circuits No.#	1		
Charge - kg	2.30	2.62	3.06
Metering Device / ORIFIC OD(mm)	Piston / 1.70	Piston / 2.08	TXV / N.A
Filter Drier Qty	1		
High Pressure Switch (Trip ±1/ Reset±1.7)- kPaG	44 / 29		
Low Pressure Switch (Trip ±0.3/ Reset±0.3)- kPaG	4 / 8		
Condenser Coil ⁽¹⁾			
Coil Type	7mm Helical Grooved Copper Tube, 0.74" Aluminum LSW Fins		
Standard Coil Material	Cu/Al		
Rows / Fins (FPI)	2 / 20		
Face Area (m ²)	0.85	0.95	1.21
Coil Test Pressure (bar)	31		
Condenser Fan & Motor			
Approx. Air Flow Rate (m ³ /hr)	5095	5349	6283
Quantity	1		
Diameter (mm) / No. of Blades	508 / 3		508 / 4
Motor Type	Induction Motor - Totally Enclosed		
Motor HP - RPS	1/4 - 43		1/3 - 43
Evaporator Coil ⁽²⁾			
Coil Type	3/8" Helical Grooved Copper Tube, 0.75" Aluminum LSW Fins		
Standard Coil Material	Cu/Al		
Rows / FPI	3 / 12		
Face Area (m ²)	0.40	0.46	0.57
Coil Test Pressure (bar)	23.8		
Drain Pan Connection Size (mm)	19		
Return Air Filter Qty / Size (mm) - Recommended ⁽³⁾	1/ 610x762x25		1/ 610x914x25
Evaporator Fan and Motor Section			
Fan Quantity	1		
Fan Size (Diam. x L) (in)	11.0 x 9.0		12.0 x 10.5
Fan Type	Centrifugal - Forward Blade		
Drive Type	Direct Drive		
Motor Type	Electronically Commutated (ECM)		
Indoor Motor Factory Speed Setting	Medium		
Motor Quantity	1		
Maximum HP - Maximum Watt	1/2 - 530	3/4 - 780	1 - 1050
FLA	4.1	6.0	7.6
Efficiency %	78.5	80.0	79.0
No. Of Taps	3 - [1 (Low) - 2 (Medium) - 3 (High)]		
Tap Torque (OZ Ft) [L - M - H]	26.20 - 30.27 - 34.98	43.06 - 45.88 - 58.12	42.98 - 45.80 - 54.90
% of Full Output @ Tap [L - M - H]	65.49 - 75.69 - 87.45	71.76 - 76.47 - 96.86	53.73 - 57.25 - 68.63
Motor OFF- Delay (sec.) @ Tap [L - M - H]	60 - 30 - 0		
Nominal Air Flow Rate (CFM)	1350	1600	1800
External Static Pressure (In.W.G)	Up to 1.0"		
RPM Range	600 - 1200		
Motor Frame Size	NEMA Size - 48 Motor		

(1) Condenser Copper Coils : 21 FPI

(2) Evaporator Copper Coils : 13 FPI

(3) Field Supplied - Field Installed Filter (Installed Outside The Unit In The Return Duct)

BASE UNIT DIMENSIONS – 50ZPM Series

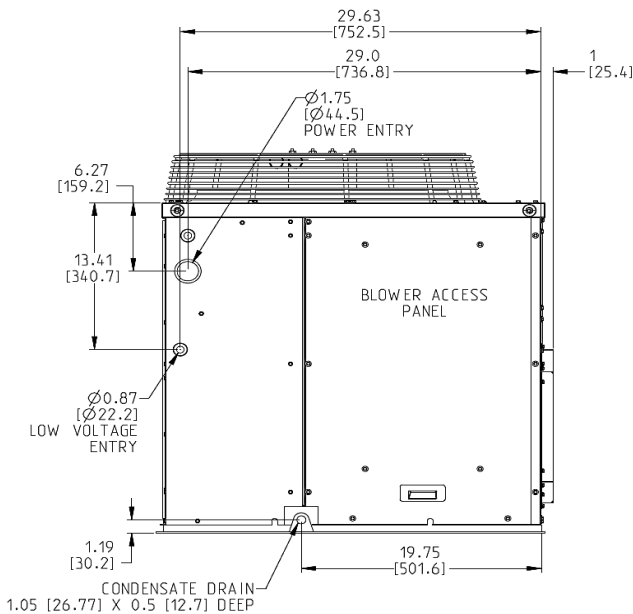
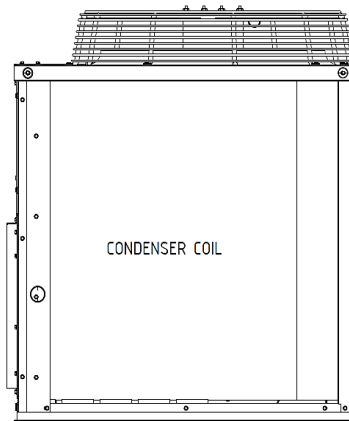
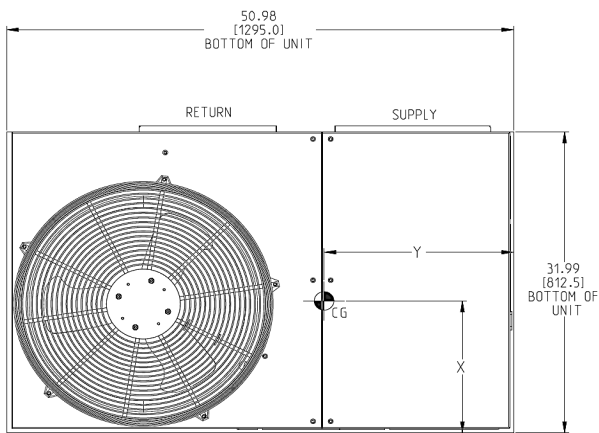
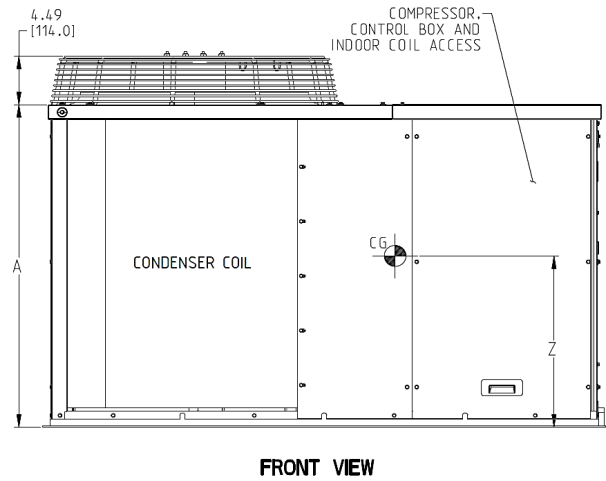
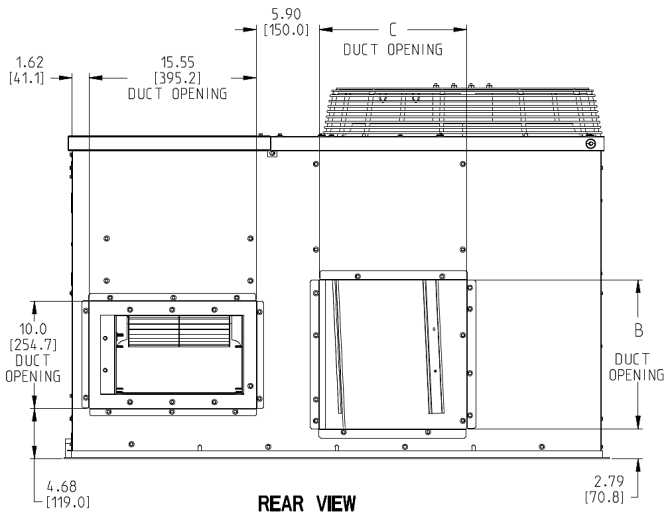

NEC REQUIRED CLEARANCE	INCHES [MM]
BETWEEN UNITS, POWER ENTRY SIDE.....	42.0 [1067]
UNIT AND UNGROUNDED SURFACES, POWER ENTRY SIDE.....	36.0 [914]
UNIT AND BLOCK OR CONCRETE WALLS AND OTHER GROUNDED SURFACES, POWER ENTRY SIDE.....	42.0 [1067]
SIDE OF UNIT WITH DUCT OPENING.....	0

REQUIRED CLEARANCE FOR SERVICING	INCHES [MM]
TOP OF UNIT.....	36.0 [914]
SIDE OF UNIT OPPOSITE DUCT OPENINGS.....	30.0 [762]
SIDE OF UNIT WITH POWER ENTRY.....	30.0 [762]
(EXCEPT FOR NEC REQUIREMENTS)	

NEC - NATIONAL ELECTRIC CODE

- NOTE:
- CLEARANCE MUST BE MAINTAINED TO PREVENT RECIRCULATION OF AIR FROM OUTDOOR FAN DISCHARGE. A REMOVAL FENCE OR BARRICADE REQUIRES NO CLEARANCE.
 - DIMENSIONS ARE IN INCHES. DIMENSIONS IN [] ARE IN MILLIMETERS.

Unit 50ZPM	Unit Weight		Unit Height	Duct Opening			Center of Gravity (mm)		
	LBS.	KG.	A	B	C	X	Y	Z	
36	279	127	30.12 [765]	14.0 [357.7]	13.7 [348]	14 [356]	19 [483]	14.0 [356]	
48	305	139	34.13 [867]	19.9 [506.14]	13.9 [354]	14 [356]	19 [483]	16.0 [406]	
60	352	160	42.13 [1070]	19.9 [506.14]	13.9 [354]	14 [356]	19 [483]	19.8 [503]	

- Center Of Gravity

SELECTION PROCEDURE

A. DETERMINE COOLING AND HEATING REQUIREMENTS AT DESIGN CONDITIONS.

Given:

- Required Cooling Capacity (TC) 34,000 Btuh
- Sensible Heat Capacity (SHC) 25,000 Btuh
- Required Heating Capacity 15,000 Btuh
- Outdoor Entering-Air Temperature 95° F (35° C)
- Indoor Entering-Air Temperature . . . 80° F edb (26.7° C); 67° F (19.4° C) ewb
- Indoor-Air Quantity 1200 CFM
- External Static Pressure 0.20 in. wg.
- Electrical Characteristics (V- Ph-Hz) 230- 1- 60

B. SELECT UNIT BASED ON REQUIRED COOLING CAPACITY. (Values given are indicative only not actual)

Enter Cooling Capacities table at condenser entering temperature of 95°F (35° C), indoor air entering at 1200 CFM and 67° F (19.4° C) ewb. The 50ZPM36 unit provides a total cooling capacity of 36,285 Btuh and a sensible heat capacity of 27,454 Btuh. For indoor- air temperature other than 80° F (26.7° C) edb, calculate sensible heat capacity correction, as required, using the formula found following the Cooling Capacities tables.

C. SELECT ELECTRIC HEAT.

The required heating capacity is 15,000 Btuh (given). Determine the electric heat capacity in kW.

15,000 Btuh = 3.8 kW of heat required
3414 Btuh/kW

Enter the Accessory Electric Heater table, single- phase, 50ZPM unit. The 4.59- kW heater at 230v most closely satisfies the heating required.

4.59 kW x 3414 Btuh/kW = 15,670 Btuh

D. DETERMINE FAN SPEED AND POWER REQUIREMENTS AT DESIGN CONDITIONS.

Before entering the air delivery tables, calculate the total static pressure required. From the given, Filter Pressure Drop table and the Accessory Electric Heat Pressure Drop table find:

- External static pressure 0.20 in. wg.
- Filter 0.07 in. wg. (Carrier Recommended) Electric Heat 0.042 in. wg.
- Total static pressure 0.372 in. wg.

Enter the table for Coil Air Delivery. At 0.37 in. wg. external static pressure and medium speed, the motor delivers 1231 CFM.

Note:

1. Cooling capacities are gross and do not include deductions for indoor fan motor heat.
2. Filter static pressure depends on your filter selection.

COOLING CAPACITIES

50ZPM - 36 - (230V) - English

Temp (F) Air Entering Condenser (Edb)		Evaporator Air - CFM/BPF											
		1050 / 0.256				1200 / 0.289				1350 / 0.300			
		Evaporator Air - EWB (F)											
		57	62	67	72	57	62	67	72	57	62	67	72
75	TC	32,465	34,066	37,728	41,481	34,269	35,152	38,647	42,481	35,508	35,857	39,411	43,297
	SHC	32,465	30,556	25,748	21,059	34,269	32,338	27,363	22,127	35,508	33,969	28,968	23,174
	kW	1.68	1.69	1.74	1.77	1.71	1.72	1.75	1.78	1.72	1.73	1.75	1.79
85	TC	30,908	31,846	35,790	39,745	32,415	32,822	36,908	40,664	33,739	33,920	37,664	41,398
	SHC	30,907	29,330	25,039	20,470	32,415	31,252	26,918	21,558	33,739	33,295	28,401	22,568
	kW	1.92	1.92	1.96	2.02	1.93	1.93	2.00	2.03	1.94	1.94	2.00	2.04
95	TC	29,329	29,706	33,388	37,595	30,667	31,296	34,381	38,726	31,868	32,284	35,104	39,395
	SHC	29,329	28,106	24,214	19,769	30,667	29,142	25,966	20,924	31,867	30,745	27,563	21,929
	kW	2.18	2.18	2.21	2.27	2.19	2.20	2.22	2.31	2.20	2.20	2.23	2.32
105	TC	27,603	27,987	30,900	34,961	28,868	29,143	31,644	35,836	29,954	29,948	32,271	36,553
	SHC	27,603	26,841	23,330	18,893	28,868	28,220	24,995	19,984	29,954	29,948	26,577	21,011
	kW	2.47	2.47	2.49	2.53	2.48	2.48	2.50	2.54	2.49	2.49	2.51	2.56
115	TC	25,701	26,083	28,290	32,029	26,875	26,869	28,954	32,861	27,894	27,885	29,467	33,526
	SHC	25,701	24,992	22,387	17,913	26,875	26,869	24,025	18,999	27,894	27,885	25,504	20,019
	kW	2.78	2.78	2.80	2.83	2.79	2.79	2.81	2.84	2.80	2.80	2.81	2.85
120	TC	24,695	24,687	26,909	30,578	25,830	25,816	27,524	31,294	26,798	26,782	27,999	31,938
	SHC	24,695	24,687	21,877	17,421	25,830	25,816	23,504	18,477	26,798	26,782	24,885	19,496
	kW	2.94	2.94	2.96	3.00	2.95	2.95	2.97	3.00	2.96	2.96	2.97	3.01
125	TC	23,646	23,646	25,486	29,112	24,744	24,729	26,023	29,789	25,663	25,662	26,526	30,326
	SHC	23,646	23,646	21,350	16,923	24,743	24,729	22,824	17,970	25,663	25,662	24,323	18,958
	kW	3.10	3.10	3.12	3.16	3.12	3.12	3.13	3.17	3.13	3.13	3.13	3.17

50ZPM - 36 - (230V) - SI

Temp (F) Air Entering Condenser (Edb)		Evaporator Air - (L/s)/BPF											
		496 / 0.256				566 / 0.289				637 / 0.300			
		Evaporator Air - EWB (C)											
		14	17	19	22	14	17	19	22	14	17	19	22
24	TC	9.5	10.0	11.1	12.2	10.0	10.3	11.3	12.4	10.4	10.5	11.6	12.7
	SHC	9.5	9.0	7.5	6.2	10.0	9.5	8.0	6.5	10.4	10.0	8.5	6.8
	kW	1.68	1.69	1.74	1.77	1.71	1.72	1.75	1.78	1.72	1.73	1.75	1.79
29	TC	9.1	9.3	10.5	11.6	9.5	9.6	10.8	11.9	9.9	9.9	11.0	12.1
	SHC	9.1	8.6	7.3	6.0	9.5	9.2	7.9	6.3	9.9	9.8	8.3	6.6
	kW	1.92	1.92	1.96	2.02	1.93	1.93	2.00	2.03	1.94	1.94	2.00	2.04
35	TC	8.6	8.7	9.8	11.0	9.0	9.2	10.1	11.3	9.3	9.5	10.3	11.5
	SHC	8.6	8.2	7.1	5.8	9.0	8.5	7.6	6.1	9.3	9.0	8.1	6.4
	kW	2.18	2.18	2.21	2.27	2.19	2.20	2.22	2.31	2.20	2.20	2.23	2.32
40.6	TC	8.1	8.2	9.1	10.2	8.5	8.5	9.3	10.5	8.8	8.8	9.5	10.7
	SHC	8.1	7.9	6.8	5.5	8.5	8.3	7.3	5.9	8.8	8.8	7.8	6.2
	kW	2.47	2.47	2.49	2.53	2.48	2.48	2.50	2.54	2.49	2.49	2.51	2.56
46	TC	7.5	7.6	8.3	9.4	7.9	7.9	8.5	9.6	8.2	8.2	8.6	9.8
	SHC	7.5	7.3	6.6	5.2	7.9	7.9	7.0	5.6	8.2	8.2	7.5	5.9
	kW	2.78	2.78	2.80	2.83	2.79	2.79	2.81	2.84	2.80	2.80	2.81	2.85
49	TC	7.2	7.2	7.9	9.0	7.6	7.6	8.1	9.2	7.9	7.8	8.2	9.4
	SHC	7.2	7.2	6.4	5.1	7.6	7.6	6.9	5.4	7.9	7.8	7.3	5.7
	kW	2.94	2.94	2.96	3.00	2.95	2.95	2.97	3.00	2.96	2.96	2.97	3.01
52	TC	6.9	6.9	7.5	8.5	7.3	7.2	7.6	8.7	7.5	7.5	7.8	8.9
	SHC	6.9	6.9	6.3	5.0	7.3	7.2	6.7	5.3	7.5	7.5	7.1	5.6
	kW	3.10	3.10	3.12	3.16	3.12	3.12	3.13	3.17	3.13	3.13	3.13	3.17

LEGEND

BPF — Bypass Factor
 Edb — Entering Dry-Bulb
 Ewb — Entering Wet-Bulb
 SHC — Sensible Heat Capacity (1000 Btuh) - Gross
Bold, Italics - Standard Ratings
 Notes:
 1. Direct interpolation is permissible. Do not extrapolate.
 2. The following formulas may be used.

Ldb — Leaving Dry-Bulb
 Lwb — Leaving Wet-Bulb
 TC — Total Capacity (1000 Btuh) - Gross
 kW — Compressor Motor Power Input

$$t_{ldb} = t_{edb} - \frac{\text{sensible capacity (Btuh)}}{1.10 \times \text{cfm}} \quad \quad \quad t_{lwb} = t_{ewb} - \frac{\text{total capacity (Btuh)}}{4.5 \times \text{cfm}}$$

t_{lwb} = Wet-bulb temperature corresponding to enthalpy of air leaving evaporator coil (t_{lwb}).

t_{ewb} = Enthalpy of air entering evaporator coil.

3. The SHC is based on 80 F edb temperature of air entering evaporator coil.

- Below 80 F edb, subtract (corr factor x cfm) from SHC. - Above 80 F edb, add (corr factor x cfm) to SHC.

BF	ENTERING AIR DRY-BULB TEMP (F)					
	79	78	77	76	75	under 75
	81	82	83	84	85	over 85
Correction Factor						
0.05	1.04	2.07	3.11	4.14	5.18	Use formula shown*
0.10	0.98	1.96	2.94	3.92	4.90	
0.20	0.87	1.74	2.62	3.49	4.36	
0.30	0.76	1.53	2.29	3.05	3.82	

- Interpolation is permissible.

*Correction Factor = 1.10 x (1 - BF) x (edb - 80).

4. Cooling capacities are gross and do not include deductions for indoor fan motor heat.

COOLING CAPACITIES (Continued)

50ZPM - 48 - (230V) - English

Temp (F) Air Entering Condenser (Edb)		Evaporator Air - CFM/BPF											
		1400 / 0.183				1600 / 0.206				1750 / 0.224			
		Evaporator Air - EWB (F)											
		57	62	67	72	57	62	67	72	57	62	67	72
75	TC	46,960	49,367	54,181	59,306	49,644	50,885	55,649	60,850	51,525	52,217	57,096	62,348
	SHC	45,731	42,504	36,055	29,403	48,343	45,838	38,610	31,052	50,194	47,930	40,782	32,718
	kW	2.75	2.78	2.80	2.83	2.78	2.79	2.81	2.84	2.78	2.79	2.81	2.84
85	TC	44,508	45,888	51,804	56,761	46,835	47,429	53,101	58,146	48,934	49,833	54,514	59,578
	SHC	43,345	41,187	35,234	28,569	45,610	44,089	37,735	30,178	47,673	46,910	39,909	31,825
	kW	3.07	3.08	3.16	3.19	3.10	3.10	3.17	3.20	3.11	3.14	3.17	3.20
95	TC	42,052	42,621	47,805	54,010	44,125	44,205	49,399	55,265	45,986	46,283	51,594	56,639
	SHC	40,955	39,381	33,806	27,643	42,973	42,739	36,449	29,230	44,805	44,794	38,905	30,873
	kW	3.43	3.44	3.49	3.58	3.43	3.45	3.52	3.59	3.45	3.46	3.55	3.60
105	TC	39,398	39,717	44,009	49,817	41,350	41,445	45,207	52,041	43,122	43,676	46,537	53,401
	SHC	38,372	37,960	32,436	26,235	40,273	40,265	34,964	28,153	42,018	41,956	37,134	29,798
	kW	3.80	3.82	3.87	3.94	3.82	3.84	3.88	4.00	3.83	3.85	3.89	4.01
115	TC	36,573	36,674	40,165	45,517	38,396	38,593	41,209	46,772	40,104	40,296	42,442	48,163
	SHC	35,624	35,622	31,029	24,784	37,399	37,390	33,513	26,422	39,081	39,068	35,608	28,094
	kW	4.23	4.25	4.29	4.36	4.25	4.27	4.30	4.38	4.26	4.28	4.31	4.39
120	TC	33,408	33,498	36,324	41,337	35,089	35,199	37,207	42,419	36,686	36,869	38,462	43,731
	SHC	32,544	32,537	28,848	22,949	34,181	34,174	31,127	24,482	35,755	35,743	33,233	26,101
	kW	4.35	4.37	4.41	4.47	4.38	4.39	4.42	4.49	4.39	4.40	4.43	4.50
125	TC	30,690	30,777	32,984	37,747	32,220	32,399	33,829	38,708	33,780	33,956	35,020	39,937
	SHC	29,900	29,893	26,998	21,397	31,389	31,381	29,217	22,854	32,928	32,917	31,158	24,424
	kW	4.67	4.68	4.72	4.79	4.69	4.71	4.73	4.80	4.70	4.72	4.74	4.81

50ZPM - 48 - (230V) - SI

Temp (F) Air Entering Condenser (Edb)		Evaporator Air - (L/s)/BPF											
		661 / 0.183				755 / 0.206				826 / 0.224			
		Evaporator Air - EWB (C)											
		14	17	19	22	14	17	19	22	14	17	19	22
24	TC	13.8	14.5	15.9	17.4	14.5	14.9	16.3	17.8	15.1	15.3	16.7	18.3
	SHC	13.4	12.5	10.6	8.6	14.2	13.4	11.3	9.1	14.7	14.0	12.0	9.6
	kW	2.75	2.78	2.80	2.83	2.78	2.79	2.81	2.84	2.78	2.79	2.81	2.84
29	TC	13.0	13.4	15.2	16.6	13.7	13.9	15.6	17.0	14.3	14.6	16.0	17.5
	SHC	12.7	12.1	10.3	8.4	13.4	12.9	11.1	8.8	14.0	13.7	11.7	9.3
	kW	3.07	3.08	3.16	3.19	3.10	3.10	3.17	3.20	3.11	3.14	3.17	3.20
35	TC	12.3	12.5	14.0	15.8	12.9	13.0	14.5	16.2	13.5	13.6	15.1	16.6
	SHC	12.0	11.5	9.9	8.1	12.6	12.5	10.7	8.6	13.1	13.1	11.4	9.0
	kW	3.43	3.44	3.49	3.58	3.43	3.45	3.52	3.59	3.45	3.46	3.55	3.60
40.6	TC	11.5	11.6	12.9	14.6	12.1	12.1	13.2	15.3	12.6	12.8	13.6	15.7
	SHC	11.2	11.1	9.5	7.7	11.8	11.8	10.2	8.3	12.3	12.3	10.9	8.7
	kW	3.80	3.82	3.87	3.94	3.82	3.84	3.88	4.00	3.83	3.85	3.89	4.01
46	TC	10.7	10.7	11.8	13.3	11.3	11.3	12.1	13.7	11.8	11.8	12.4	14.1
	SHC	10.4	10.4	9.1	7.3	11.0	11.0	9.8	7.7	11.5	11.5	10.4	8.2
	kW	4.23	4.25	4.29	4.36	4.25	4.27	4.30	4.38	4.26	4.28	4.31	4.39
49	TC	9.8	9.8	10.6	12.1	10.3	10.3	10.9	12.4	10.8	10.8	11.3	12.8
	SHC	9.5	9.5	8.5	6.7	10.0	10.0	9.1	7.2	10.5	10.5	9.7	7.6
	kW	4.35	4.37	4.41	4.47	4.38	4.39	4.42	4.49	4.39	4.40	4.43	4.50
52	TC	9.0	9.0	9.7	11.1	9.4	9.5	9.9	11.3	9.9	10.0	10.3	11.7
	SHC	8.8	8.8	7.9	6.3	9.2	9.2	8.6	6.7	9.7	9.6	9.1	7.2
	kW	4.67	4.68	4.72	4.79	4.69	4.71	4.73	4.80	4.70	4.72	4.74	4.81

LEGEND

- BPF — Bypass Factor
- Edb — Entering Dry-Bulb
- Ewb — Entering Wet-Bulb
- SHC — Sensible Heat Capacity (1000 Btuh) - Gross
- TC — Total Capacity (1000 Btuh) - Gross
- kW — Compressor Motor Power Input
- Ldb — Leaving Dry-Bulb
- Lwb — Leaving Wet-Bulb

Bold, Italics - Standard Ratings

Notes:

1. Direct interpolation is permissible. Do not extrapolate.
2. The following formulas may be used.

$$t_{ldb} = t_{edb} - \frac{\text{sensible capacity (Btuh)}}{1.10 \times \text{cfm}} \quad \quad \quad h_{lwb} = h_{ewb} - \frac{\text{total capacity (Btuh)}}{4.5 \times \text{cfm}}$$

t_{lwb} = Wet-bulb temperature corresponding to enthalpy of air leaving evaporator coil (h_{lwb}).

h_{ewb} = Enthalpy of air entering evaporator coil.

3. The SHC is based on 80 F edb temperature of air entering evaporator coil.

- Below 80 F edb, subtract (corr factor x cfm) from SHC.

- Above 80 F edb, add (corr factor x cfm) to SHC.

ENTERING AIR DRY-BULB TEMP (F)						
BF	79	78	77	76	75	under 75
	81	82	83	84	85	over 85
Correction Factor						
0.05	1.04	2.07	3.11	4.14	5.18	Use formula shown*
0.10	0.98	1.96	2.94	3.92	4.90	
0.20	0.87	1.74	2.62	3.49	4.36	
0.30	0.76	1.53	2.29	3.05	3.82	

- Interpolation is permissible.

*Correction Factor = 1.10 x (1 - BF) x (edb - 80).

4. Cooling capacities are gross and do not include deductions for indoor fan motor heat.

COOLING CAPACITIES (Continued)

50ZPM - 60 - (230V) - English

Temp (F) Air Entering Condenser (Edb)		Evaporator Air - CFM/BPF											
		1650 / 0.142				1800 / 0.171				2000 / 0.199			
		Evaporator Air - EWB (F)											
		57	62	67	72	57	62	67	72	57	62	67	72
75	TC	55,507	55,848	60,922	66,282	57,294	57,951	61,829	67,318	58,533	58,785	62,252	67,852
	SHC	53,298	50,175	42,702	34,391	55,020	53,324	45,124	35,883	56,215	55,611	47,036	37,032
	kW	3.31	3.33	3.37	3.41	3.44	3.45	3.49	3.54	3.60	3.62	3.66	3.70
85	TC	53,529	53,561	58,457	63,616	55,210	55,217	59,266	64,525	56,363	56,606	59,552	64,924
	SHC	51,401	48,818	42,021	33,592	53,021	53,161	44,457	35,081	54,133	54,130	46,313	36,207
	kW	3.68	3.70	3.73	3.77	3.79	3.81	3.85	3.90	3.96	3.98	4.02	4.07
95	TC	51,403	51,476	55,728	60,743	52,962	53,157	56,402	61,503	54,012	54,255	56,591	61,825
	SHC	49,360	48,585	41,031	32,675	50,865	50,863	43,438	34,139	51,878	51,875	45,297	35,272
	kW	4.08	4.09	4.12	4.17	4.19	4.21	4.25	4.30	4.37	4.38	4.42	4.46
105	TC	49,155	49,238	52,806	57,638	50,600	50,795	53,366	58,290	51,555	51,769	53,610	58,502
	SHC	47,205	47,189	39,909	31,627	48,598	48,596	42,268	33,088	49,521	49,519	44,488	34,219
	kW	4.46	4.47	4.51	4.56	4.59	4.60	4.64	4.68	4.76	4.77	4.80	4.85
115	TC	46,747	46,844	49,691	54,279	48,072	48,267	50,187	54,797	48,921	49,065	50,330	54,950
	SHC	44,894	44,893	38,731	30,480	46,173	46,172	41,224	31,928	46,994	46,991	43,148	33,068
	kW	5.17	5.19	5.22	5.27	5.31	5.33	5.35	5.40	5.49	5.50	5.52	5.57
120	TC	43,946	44,040	46,440	50,713	45,163	45,352	46,885	51,165	45,906	46,168	46,999	51,274
	SHC	43,693	43,693	38,115	29,877	44,904	44,904	40,550	31,319	45,644	45,643	42,495	32,459
	kW	5.22	5.24	5.27	5.31	5.35	5.37	5.39	5.43	5.53	5.54	5.56	5.60
125	TC	41,180	41,271	43,241	47,199	42,288	42,470	43,622	47,611	42,946	43,082	43,701	47,680
	SHC	41,203	41,202	36,475	28,409	42,311	42,310	38,729	29,819	42,969	42,968	40,530	30,927
	kW	5.58	5.60	5.63	5.67	5.72	5.73	5.75	5.79	5.90	5.91	5.92	5.96

50ZPM - 60 - (230V) - SI

Temp (F) Air Entering Condenser (Edb)		Evaporator Air - (L/s)/BPF											
		779 / 0.142				850 / 0.171				944 / 0.199			
		Evaporator Air - EWB (C)											
		14	17	19	22	14	17	19	22	14	17	19	22
24	TC	16.3	16.4	17.9	19.4	16.8	17.0	18.1	19.7	17.2	17.2	18.2	19.9
	SHC	15.6	14.7	12.5	10.1	16.1	15.6	13.2	10.5	16.5	16.3	13.8	10.9
	kW	3.31	3.33	3.37	3.41	3.44	3.45	3.49	3.54	3.60	3.62	3.66	3.70
29	TC	15.7	15.7	17.1	18.6	16.2	16.2	17.4	18.9	16.5	16.6	17.5	19.0
	SHC	15.1	14.3	12.3	9.8	15.5	15.6	13.0	10.3	15.9	15.9	13.6	10.6
	kW	3.68	3.70	3.73	3.77	3.79	3.81	3.85	3.90	3.96	3.98	4.02	4.07
35	TC	15.1	15.1	16.3	17.8	15.5	15.6	16.5	18.0	15.8	15.9	16.6	18.1
	SHC	14.5	14.2	12.0	9.6	14.9	14.9	12.7	10.0	15.2	15.2	13.3	10.3
	kW	4.08	4.09	4.12	4.17	4.19	4.21	4.25	4.30	4.37	4.38	4.42	4.46
40.6	TC	14.4	14.4	15.5	16.9	14.8	14.9	15.6	17.1	15.1	15.2	15.7	17.1
	SHC	13.8	13.8	11.7	9.3	14.2	14.2	12.4	9.7	14.5	14.5	13.0	10.0
	kW	4.46	4.47	4.51	4.56	4.59	4.60	4.64	4.68	4.76	4.77	4.80	4.85
46	TC	13.7	13.7	14.6	15.9	14.1	14.1	14.7	16.1	14.3	14.4	14.8	16.1
	SHC	13.2	13.2	11.4	8.9	13.5	13.5	12.1	9.4	13.8	13.8	12.6	9.7
	kW	5.17	5.19	5.22	5.27	5.31	5.33	5.35	5.40	5.49	5.50	5.52	5.57
49	TC	12.9	12.9	13.6	14.9	13.2	13.3	13.7	15.0	13.5	13.5	13.8	15.0
	SHC	12.8	12.8	11.2	8.8	13.2	13.2	11.9	9.2	13.4	13.4	12.5	9.5
	kW	5.22	5.24	5.27	5.31	5.35	5.37	5.39	5.43	5.53	5.54	5.56	5.60
52	TC	12.1	12.1	12.7	13.8	12.4	12.4	12.8	14.0	12.6	12.6	12.8	14.0
	SHC	12.1	12.1	10.7	8.3	12.4	12.4	11.4	8.7	12.6	12.6	11.9	9.1
	kW	5.58	5.60	5.63	5.67	5.72	5.73	5.75	5.79	5.90	5.91	5.92	5.96

LEGEND

BPF — Bypass Factor
 Edb — Entering Dry-Bulb
 Ewb — Entering Wet-Bulb
 SHC — Sensible Heat Capacity (1000 Btuh) - Gross
 Ldb — Leaving Dry-Bulb
 Lwb — Leaving Wet-Bulb
 TC — Total Capacity (1000 Btuh) - Gross
 kW — Compressor Motor Power Input

Bold, Italics - Standard Ratings

Notes:

- Direct interpolation is permissible. Do not extrapolate.
- The following formulas may be used.

$$t_{ldb} = t_{edb} - \frac{\text{sensible capacity (Btuh)}}{1.10 \times \text{cfm}} \quad \quad \quad h_{lwb} = h_{ewb} - \frac{\text{total capacity (Btuh)}}{4.5 \times \text{cfm}}$$

t_{lwb} = Wet-bulb temperature corresponding to enthalpy of air leaving evaporator coil (h_{lwb}).

h_{ewb} = Enthalpy of air entering evaporator coil.

- The SHC is based on 80 F edb temperature of air entering evaporator coil.

- Below 80 F edb, subtract (corr factor x cfm) from SHC.

- Above 80 F edb, add (corr factor x cfm) to SHC.

ENTERING AIR DRY-BULB TEMP (F)						
BF	79	78	77	76	75	under 75
	81	82	83	84	85	over 85
Correction Factor						
0.05	1.04	2.07	3.11	4.14	5.18	Use formula shown*
0.10	0.98	1.96	2.94	3.92	4.90	
0.20	0.87	1.74	2.62	3.49	4.36	
0.30	0.76	1.53	2.29	3.05	3.82	

- Interpolation is permissible.

*Correction Factor = 1.10 x (1 - BF) x (edb - 80).

- Cooling capacities are gross and do not include deductions for indoor fan motor heat.

PERFORMANCE AND ACCESSORIES

Standard Air Flow Rate Delivery Table At Wet Coil - Without Air Filter*

50ZPM Unit Size	Speed Tap	External Static Pressure (in. wg.)									
		0.1	0.2	0.3	0.4	0.5	0.6	0.7	0.8	0.9	1.0
36	1	1238	1182	1140	1101	1057	1007	954	866	820	791
	2	1313	1275	1237	1191	1156	1109	1049	989	927	886
	3	1426	1391	1358	1317	1274	1233	1178	1113	1083	1052
48	1	1663	1616	1563	1513	1464	1428	1385	1347	1307	1274
	2	1713	1663	1616	1571	1531	1489	1449	1406	1371	1338
	3	1938	1889	1838	1791	1746	1709	1673	1629	1593	1565
60	1	1773	1727	1671	1624	1571	1510	1437	1383	1336	1273
	2	1844	1798	1749	1699	1638	1579	1512	1449	1400	1344
	3	2025	1984	1936	1890	1833	1769	1697	1642	1605	1545

* Rated Table based on operating Voltage of 230. Deduct 10% for 208 application voltage.

Air Filter Pressure Drop (in. wg.)

Filter Size inch (mm)*	Air Flow Rate (CFM)							
	700	800	900	1000	1100	1200	1300	1400
24x30x1 (610x762x25)	0.03	0.04	0.05	0.06	0.07	0.07	0.08	0.09
24x36x1 (610x914x25)	-	-	-	-	-	0.06	0.07	0.07

* Throwaway Installed Field Filter

Air Filter Pressure Drop (in. wg.)

Filter Size inch (mm)*	Air Flow Rate (CFM)						
	1500	1600	1700	1800	1900	2000	2100
24x30x1 (610x762x25)	0.1	-	-	-	-	-	-
24x36x1 (610x914x25)	0.08	0.09	0.09	0.1	0.11	0.12	0.13

* Throwaway Installed Field Filter

Accessory Electric Heater Pressure Drop (in. wg.)

Heater kW	Air Flow Rate (CFM)						
	800	1000	1200	1400	1600	1800	2000
4.6-18.4	0.033	0.037	0.042	0.047	0.052	0.060	0.067

Accessory Electric Heaters (230-1Phz-60Hz)

Catalogue Ordering Number*	Application Capacity (KW)	Used With Sizes				
		Circuit Breaker	Stages	36	48	60
CPHEATER125A02	4.6	No	1	√	√	√
CPHEATER126A02	4.6	Yes	1	√	√	√
CPHEATER127A02	6.9	No	2	√	√	√
CPHEATER128A02	6.9	Yes	2	√	√	√
CPHEATER129A02	9.2	No	2	√	√	
CPHEATER130A02	9.2	Yes	2	√	√	√
CPHEATER131A02	13.8	Yes	2	√	√	√
CPHEATER132A02	18.4	Yes	2		√	√

* Note:- All nominal Heater capacity are @240V, Application Capacity calculated on 230V

ELECTRICAL DATA

50ZPM - Application			Compressor		OFM		IFM		Electric Heater		MCA	MOCP
Unit Size	Power Supply V / Ph / Hz	Min - Max Voltage	RLA	LRA	HP	FLA	HP	FLA	Appl. KW	FLA		
36	230/1/60	207 - 253	14.1	77	1/4	1.5	1/2	3.8	-	-	23.0	35
									4.59	19.9	29.6	35
									6.88	29.9	42.1	45
									9.18	39.9	54.6	60
									13.8	60.0	79.8	80
48			21.7	117	1/4	1.5	3/4	6.0	-	-	34.7	50
									4.59	19.9	34.7	50
									6.88	29.9	44.1	50
									9.18	39.9	56.6	60
									13.8	60.0	81.7	90
60			25.0	134	1/3	1.9	1	7.6	-	-	40.1	60
									4.59	19.9	40.1	60
									6.88	29.9	46.1	60
									9.18	39.9	58.6	60
									13.8	60.0	83.75	90
								18.4	80.0	108.75	110	

Legend and Notes for Electrical Data Table

- FLA** - Full Load Amps
- IFM** - Indoor (Evaporator) Fan Motor
- LRA** - Locked Rotor Amps
- MCA** - Minimum Circuit Amps
- OFM** - Outdoor (Condenser) Fan Motor
- RLA** - Rated Load Amps
- APP** - Application power at rated power supply voltage
- MOCP** - Maximum Overcurrent Protection

Unbalanced 3-Phase Supply Voltage

Never operate a motor where phase imbalance in supply voltage is greater than 2%.

Use the following formula to determine the percentage of voltage imbalance

$$= 100 \times \frac{\text{Maximum Deviation From Average Voltage}}{\text{Average Voltage}}$$

Example: Supply Voltage is 230V - 1PH - 60Hz

AB = 228v	Average Voltage = $\frac{228 + 233 + 229}{3}$
BC = 233v	
AC = 229v	$= \frac{690}{3} = 230V$

Determine maximum deviation from average voltage.

- (AB) 230 - 228 = 2v
- (BC) 233 - 230 = 3v
- (AC) 230 - 229 = 1v

Maximum Deviation is 3v.

Determine Percentage Voltage Imbalance.

$$\% \text{ Voltage Imbalance} = 100 \times \frac{3}{228} = 1.32\%$$

This amount of phase imbalance is satisfactory as it is below the maximum allowable 2%

IMPORTANT: If the supply voltage phase imbalance is more than 2% contact your local electric utility company

TYPICAL WIRING SCHEMATIC – 50ZPM – 230V-60Hz

CONNECTION WIRING DIAGRAM

DANGER: ELECTRICAL SHOCK HAZARD DISCONNECT POWER BEFORE SERVICING

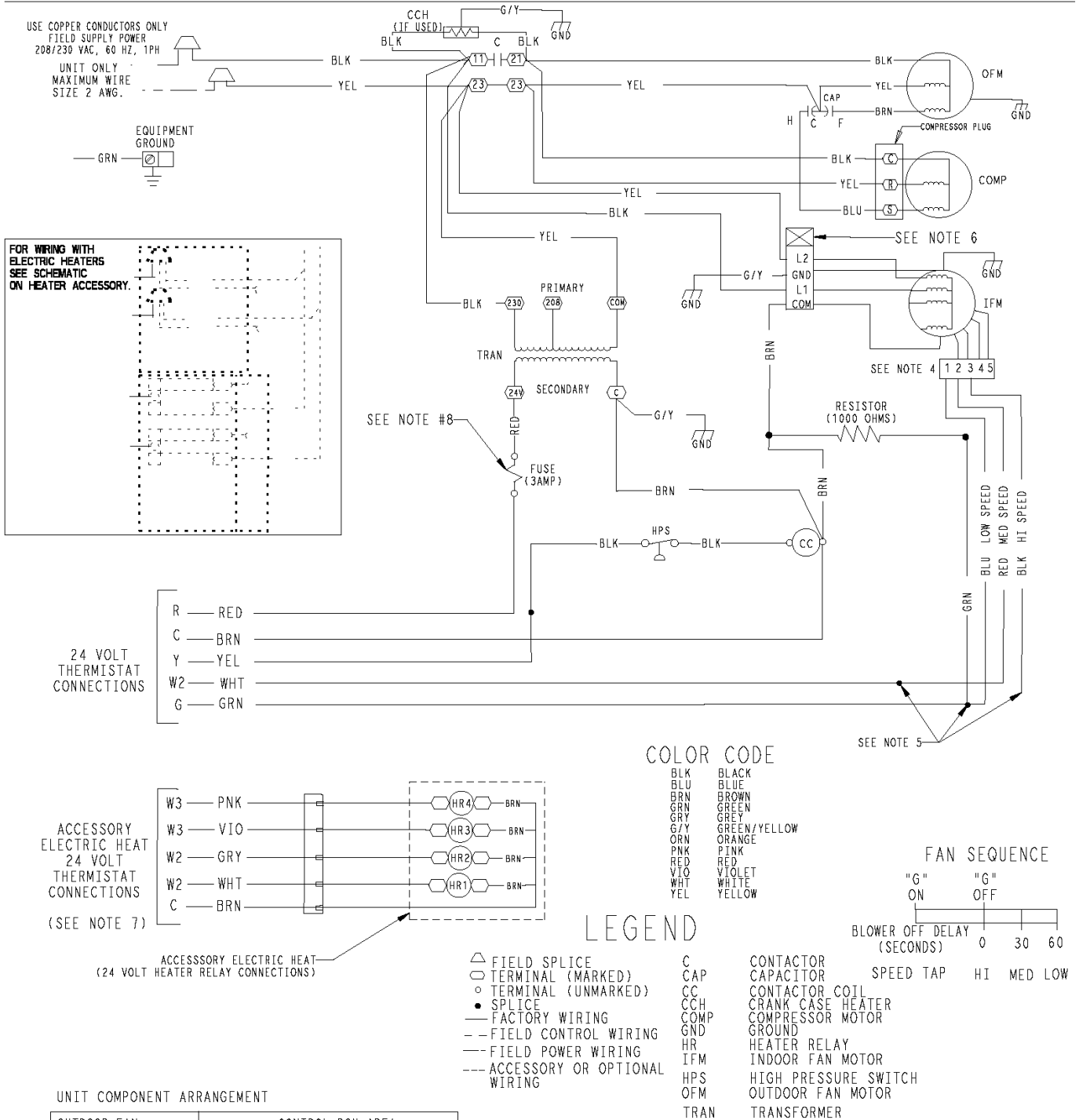

TYPICAL WIRING SCHEMATIC – 50ZPM – 230V-60Hz

LADDER WIRING DIAGRAM

DANGER: ELECTRICAL SHOCK HAZARD DISCONNECT POWER BEFORE SERVICING

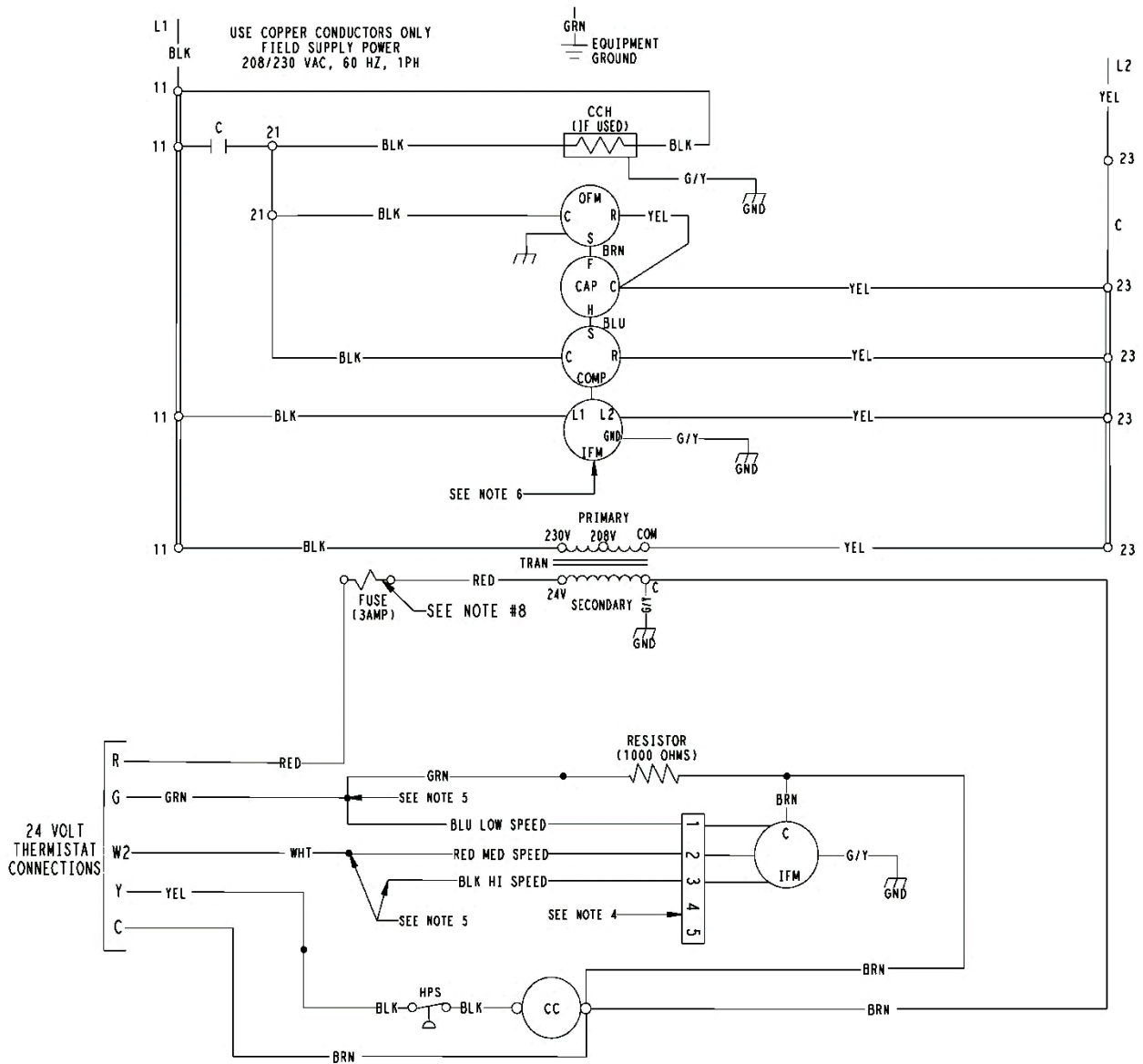

TYPICAL INSTALLATION

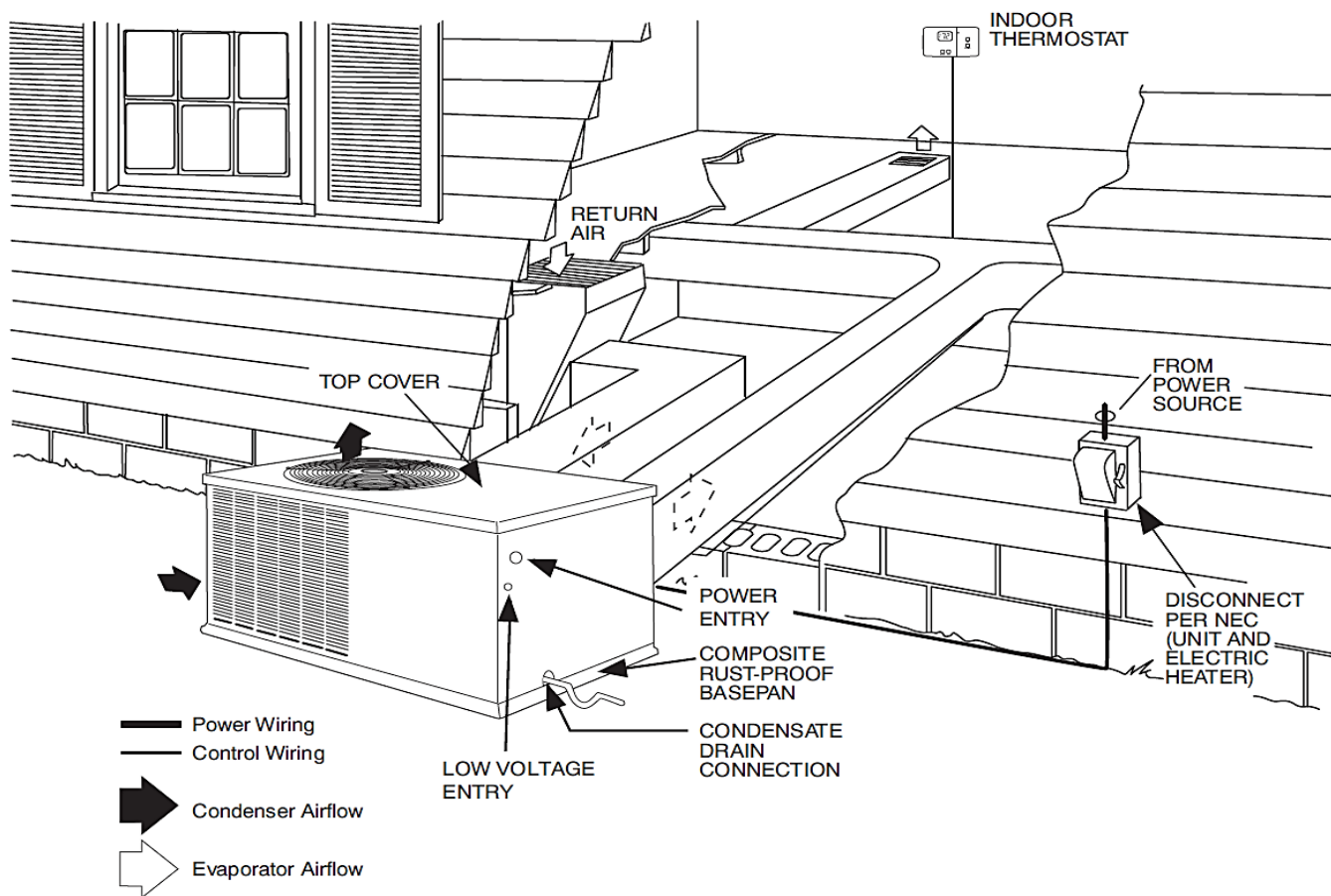

LEGEND:

NEC - National Electrical Code

NOTES:

1. All wiring must comply with the applicable local and national codes.
2. Wiring shown are general points-of-connection guides only and are not intended for, or to include all details for a specific installation.

APPLICATION DATA

Condensate trap — A 2- in. (51 mm) condensate trap must be field supplied.

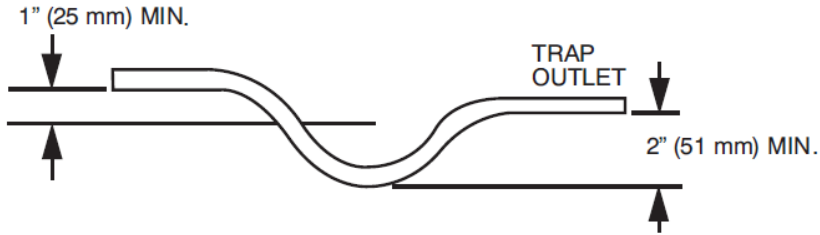

Maximum cooling airflow — To minimize the possibility of condensate blow-off from the evaporator, airflow through the units should not exceed 450 CFM/ton.

Minimum cooling airflow — The minimum cooling airflow is 350 cfm/ton.

Minimum cooling operating outdoor air temperature — All standard units have a minimum ambient operating temperature of 40°F (4.4°C).

Maximum operating outdoor air temperature — Maximum outdoor operating air temperature for cooling is 125°F (52°C).

OPERATING SEQUENCE

Cooling Operation

With a call for cooling (Y/G), the contactor is energized which brings on the compressor and outdoor fan. The indoor fan is also energized. When the cooling demand is met, Y and G are de-energized shutting off the contactor. The indoor fan stops after a 60 second delay.

Heating Operation

With a call for heating (W2), the auxiliary or electric heat energizes along with the indoor blower. In case of staged heating, W3 is energized if the demand is not met. The highest airflow selected is run while the electric heat is in operation. When heating demand is met, W3 and W2 sequentially de-energize shutting off the indoor fan and the electric heater.

Continuous Fan (Thermostat Feature)

With the continuous indoor fan option selected on the thermostat, G is continuously energized keeping the indoor fan running at all times.

GUIDE SPECIFICATIONS



Single- Packaged Air Conditioner System

50ZPM Side – Discharge Package Units

Size Range: 3.0 to 5.0 Tons

System Description

Small-Capacity Self-Contained Air Conditioners (50ZPM), electrically controlled, heating and cooling unit utilizing hermetic reciprocating or scroll compressor for cooling duty and electric for heating duty.

Quality Assurance

- A. Unit shall be designed to conform to ASHRAE 15, 2001.
- B. Unit shall be rated in accordance with applicable SASO standard
- C. Insulation and adhesive shall meet NFPA 90A requirements for flame spread and smoke generation.
- D. Unit casing shall be capable of withstanding 500-hour salt spray exposure per ASTM B117 (scribed specimen).
- E. Unit shall be designed and manufactured in a facility in accordance and registered by ISO 9001:2015.
- F. Unit shall be subjected to a completely automated run test on the assembly line. The data for each unit will be stored at the factory, and must be available upon request.
- G. Unit shall be designed in accordance with UL Standard 1995.
- H. All wiring shall be in accordance with NEC.
- I. Unit shall have a sloped drain pan that conforms to ASHRAE Standard 62.2.

Delivery, Storage, And Handling

- A. Unit shall be stored and handled per manufacturer's recommendations.
- B. Unit shall only be stored or positioned in the upright position.

Product General

- A. Factory assembled, single-piece heating and cooling rooftop unit. Contained within the unit enclosure shall be all factory wiring, piping, controls, and special features required prior to field start-up.
- B. Unit shall use environmentally safe, Puron refrigerant.
- C. Unit shall be installed in accordance with the manufacturer's instructions.
- D. Unit must be selected and installed in compliance with local, state, and federal codes.
- E. Interior cabinet surfaces shall be insulated with closed cell foam minimum ½ -in. thick, minimum density 3.1lb/ft³.

Unit Cabinet

- A. Unit cabinet shall be constructed of galvanized steel, and shall be bonderized and coated with a pre-painted baked enamel finish on all externally exposed surfaces.
- B. Unit cabinet exterior paint shall be: film thickness, (dry) 76mm minimum, gloss (per ASTM D523, 60°F): 60, Hardness: H-2H Pencil hardness, Base-pan shall be made of single piece non-corrosive, composite material. Evaporator- fan compartment interior cabinet surfaces shall be insulated with a minimum 1/2- in. (12.7 mm) thick, coated on the air side with aluminum foil.
- C. Top panel: Shall be a two piece top panel.
- D. Electrical Connections: All unit power wiring shall enter unit cabinet at a single, factory-prepared, knock out location.
- E. Component access panels shall be easily removable for servicing. Service panels shall have molded composite handles UV modified, composite, permanently attached, and recessed into the panel.

Coils

Standard Aluminum fin-Copper Tube Coils:

- A. Standard evaporator and condenser coils shall have aluminum lanced plate fins mechanically bonded to seam- less internally grooved copper tubes with all joints brazed.
- B. Evaporator coils shall be leak tested to 150 psig, pressure tested to 350 psig, and qualified to UL 1995 burst test at 1775 psig.
- C. Condenser coils shall be leak tested to 150 psig, pressure tested to 450 psig, and qualified to UL 1995 burst test at 1980 psig.

Optional Pre-coated aluminum-fin condenser coils:

- A. Shall have a durable epoxy-phenolic coating to provide protection in mildly corrosive coastal environments.
- B. Coating shall be applied to the aluminum fin stock prior to the fin stamping process to create an inert barrier between the aluminum fin and copper tube.
- C. Epoxy-phenolic barrier shall minimize galvanic action between dissimilar metals.

Optional Copper-fin evaporator and condenser coils:

Shall be constructed of copper fins mechanically bonded to copper tubes.

Compressor

Compressor shall be fully hermetic type with external vibration isolation.

Condenser Section

Condenser fan shall be of the direct- driven propeller type blades, riveted to corrosion-resistant spiders, and shall be dynamically balanced and discharge air vertically upwards. Condenser coils shall have aluminum- plate fins mechanically bonded to copper tubes with all joints brazed. Tube sheet openings shall be belled to prevent tube wear.

Evaporator Section

Fan shall be multi- speed with direct drive motor. Fan wheel shall be made from steel, double-inlet type with forward-curved blades with a corrosion-resistant finish and dynamically balanced. Evaporator coils shall have aluminum-plate fins mechanically bonded to copper tubes with all joints brazed. Tube sheet openings shall be belled to prevent tube wear.

Motors

Compressor motors shall be of the refrigerant cooled type with line break thermal and current overload protection. All fan motors shall have permanently lubricated bearings, and inherent automatic reset thermal overload protection. Condenser fan motor shall be totally enclosed.

Refrigerant System

Refrigerant system shall include fixed orifice or TXV metering system with filter drier. Service gauge connections on both suction and discharge lines.

Controls

Unit shall be complete with self- contained low voltage control circuit.

Electric and Electronic Control System for HVAC

- A. Shall be complete with self-contained low-voltage control circuit protected by a resettable circuit breaker on the 24V transformer side. Shall utilize color-coded wiring.
- B. Unit shall include a screw terminal connection board for connection of control wiring.
- C. Internal compressor over-temperature, over current.
- D. Low pressure switch.
- E. High pressure switch.
- F. Internal automatic reset, motor thermal overload protector.

Electrical Requirements

Main power supply voltage, phase, and frequency must match those required by the manufacturer.

Accessories

Field-supplied, field-installed accessories shall include thermostats, electric heaters with single-point connection and return air filters.

