



AquaEdge® 19DV Water-Cooled Centrifugal Chiller



The Ultimate BTU Machine.



The Enabler of Intelligent HVAC Design.

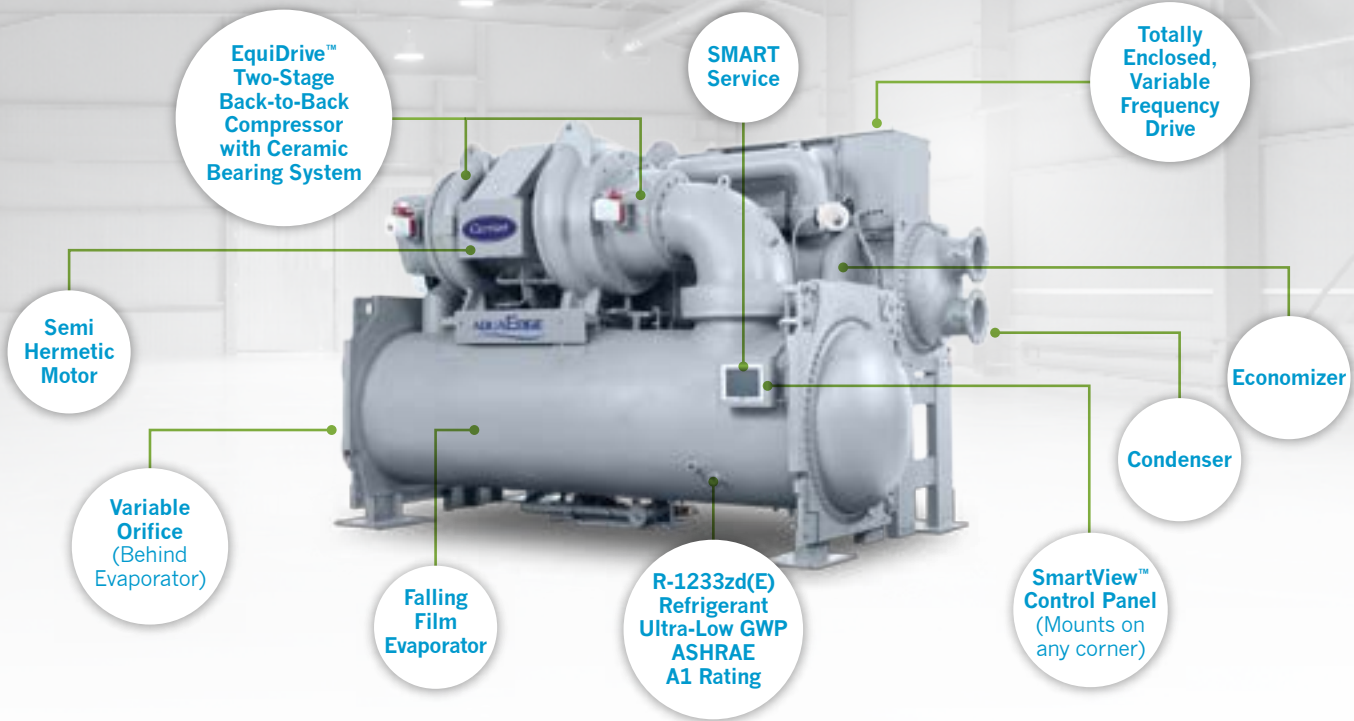

Introducing the AquaEdge® 19DV Water-Cooled Centrifugal Chiller – the Ultimate Innovation in Heating and Cooling Technology.

Every building is different. Type, usage, layout and climate all have a huge effect on heating and cooling needs, and those needs vary during different times of the year. To adapt to changes, you need a chiller that can do it all — and in ways the industry hasn't seen before.

That's why Carrier has developed the 19DV Water-Cooled Chiller with several innovative features, incredible versatility and a full-system approach to efficient cooling and heating. The result is a chiller that's so reliable, so high-performing, so future-proof that once it's installed, you may never have to think about it again.

The 19DV Chiller – Cool in Every Way Imaginable.

ULTIMATE EFFICIENCY

The 19DV is serious about efficiency, and it has the features to back it up. It delivers world-class cooling performance, but the efficiency story goes beyond just that. The 19DV's unique two-stage back-to-back compression utilizes lift optimization technology, which allows for effective heat recovery. This enables a chiller with excellent cooling efficiency at standard conditions to flex up to 120°F (48.9°C) for energy-saving hot water production. If that's not enough, the machine is able to provide free cooling, which can easily meet many new building code requirements. This can result in thousands of dollars in energy savings per year, all while reducing maintenance costs and mechanical room space. This holistic approach to energy savings results in the ultimate BTU machine.

ULTIMATE PERFORMANCE UNDER PRESSURE

While many chillers shut down when faced with stressful conditions, the 19DV's two-stage compressor with MaxFlex capability allows for continued operation under demanding conditions. That means the ultimate BTU machine keeps cool under pressure, performing reliably even outside of standard conditions.

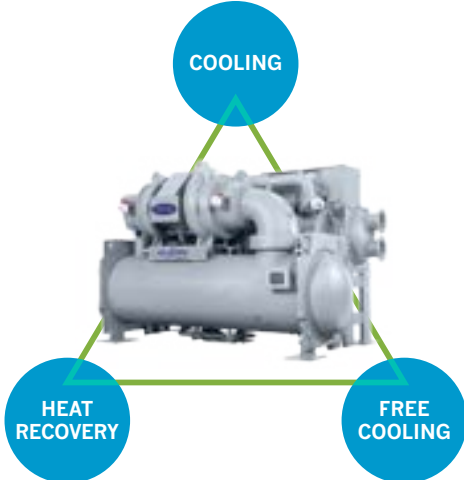

ULTIMATE RELIABILITY

The 19DV's low-speed, direct drive, back-to-back EquiDrive™ compressor technology allows for load cancellation. The simple result is bearing technology that lasts the life of the chiller. This bearing system is the ultimate in simplicity, eliminating not only an oil management system but also the controls, electronics and sensors required with magnetic bearings.

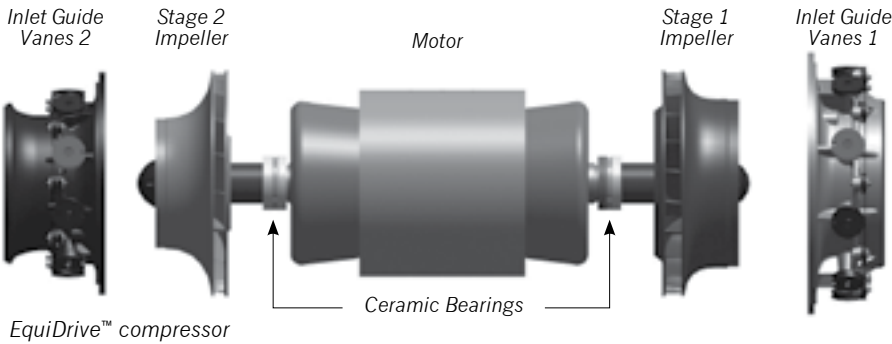

ULTIMATE SUSTAINABILITY

The 19DV is the most environmentally responsible chiller Carrier has ever made. That's due not only to world-class efficiency (on or off), but to the use of refrigerant R-1233zd(E), which provides a host of eco-friendly benefits such as ultra-low global warming potential (GWP) of ~1 and zero ozone depletion, all with an A1 safety rating (the best possible). In addition, it allows for a machine that has an efficiency that's >40% higher than ASHRAE 2016 guidelines, has low sound and is capable of series counterflow configurations.

ULTIMATE FLEXIBILITY

19DV chillers can operate with cold condenser water during periods of free cooling one day, and at 120°F (48.9°C) condenser water for heat recovery the next. To make this possible, the 19DV employs a variable orifice to ensure robust refrigerant metering and proper refrigerant levels during variable lift and load conditions, keeping operation not only possible, but efficient.

The high-performance two-stage economized EquiDrive™ compressor ensures the 19DV can operate stably from 100% to less than 10% load over a wide range of condenser temperatures. Controls leverage Greenspeed® intelligence variable-speed technology to vary the rpm, enabling the 19DV to provide a much wider operating range and still be significantly more efficient at standard AHRI® conditions than conventional chillers with limited range, as shown on the chart.

PERFORMANCE & FLEXIBILITY

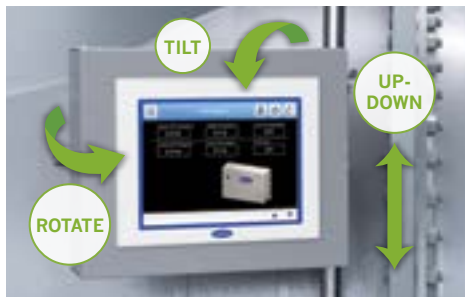
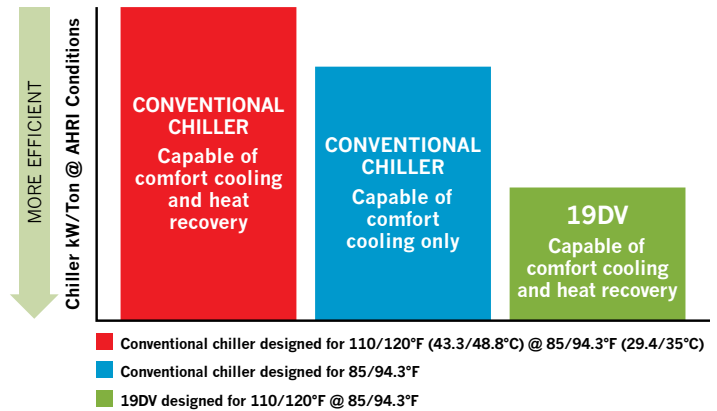

Fully adjustable in three planes of motion

ULTIMATE CONTROL AND INTELLIGENCE

The 19DV features Carrier's SmartView™ control panel, which allows intelligent control of all aspects of your cooling system. The versatile touch-screen monitor can be mounted to any of the unit's four corners.

In addition, every 19DV comes equipped with Carrier SMART Service, an internet of things (IoT) cloud based analytics platform, accessible via the web. SMART Service automatically trends, predicts and analyzes performance, allowing for a strategic approach to preventive maintenance and providing an intuitive way to monitor plant energy consumption.

ULTIMATE ENABLER OF INTELLIGENT HVAC DESIGN

While delivering unprecedented flexibility can help maintain uninterrupted comfort in conventional HVAC systems, for progressive HVAC system designs, this flexibility translates into much more. High-performance systems deliver far more energy savings than are possible by increasing mechanical equipment efficiency alone. Whether it's heat recovery tailored for high-efficiency hot water plants with condensing boilers, dual temperature systems, ground source systems, free cooling designs, series applications or extreme optimization of all variable-speed plants, the 19DV delivers the range needed.

In today's world of equipment claims, it is actually the holistic HVAC system performance that drives the bottom line. Carrier's 19DV ultimate BTU machine is the enabler of intelligent HVAC design.

Benefits at a Glance

Equipment Benefits

- EquiDrive™ compressor technology means bearings last the life of the chiller
- Robust VFD design protects against dirty power and dirty environments
- Environmentally sustainable, ultra-low GWP, A1-rated, future-proof refrigerant
- SmartView™ graphical interface with flexible mounting locations
- SMART Service intelligent analytics

System Benefits

- Ultimate design in one machine
 - High efficiency across a wide operating range that exceeds ASHRAE 90.1/FEMP standards for efficiency
 - MaxFlex capability allows operation at demanding conditions
 - Capability for:
 - Variable Flow
 - Heat Recovery
 - Free Cooling
 - Series and Parallel Plants
 - Dual Temperature Systems
 - Ground Source



Green Products Come From Green Factories

Customers can be confident that the products manufactured by Carrier are manufactured at best-in-class factories, with the goal of being energy efficient and environmentally sustainable.

The Carrier North America Chiller and Split Systems manufacturing plant, located in Charlotte, N.C., has achieved LEED® certification and is a winner of Industry Week's "Best Plants" award.



United Technologies
turn to the experts

carrier.com/19DV

Water-cooled chillers within the scope of the AHRI WCCL certification program are certified in accordance with the AHRI Water-Cooled Water-Chilling and Heat Pump Water-Heating Packages Certification Program, which is based on AHRI Standard 550/590 (I-P) and AHRI Standard 551/591 (SI). Certified units may be found in the AHRI Directory at www.ahridirectory.org.

©Carrier Corporation 2018. A unit of United Technologies Corporation. Stock symbol UTX. Manufacturer reserves the right to discontinue, or change at any time, specifications or designs without notice or without incurring obligations. Cat. No. 04-811-50056